

## S130 and M150 Single-jet and multi-jet warm water meters

<b>Permanent flow rate qp</b>	<b>S130</b>	<b>m<sup>3</sup>/h</b>	1.5	2.5	–	–	–
<b>Permanent flow rate qp</b>	<b>M150</b>	<b>m<sup>3</sup>/h</b>	1.5	2.5	3.5	6	10
<b>Size</b>		<b>mm</b>	15	20	25	30	40
<b>Maximum working temperature</b>			90°C				

The S130 is a single-jet inferential warm water meter with a dry dial register. Its balanced hydraulic design gives a wide measuring range with a good low flow performance. The rotor and undergear are the only wetted moving parts and a magnetic coupling transmits the drive from the rotor to the hermetically sealed register.

The M150 is a multi-jet warm water meter with a dry dial register. It operates on the velocity principle in which water enters the measuring chamber through a number of ports and drives the inner rotor. This movement is transmitted by a magnetic coupling to the register which displays the total quantity passed.

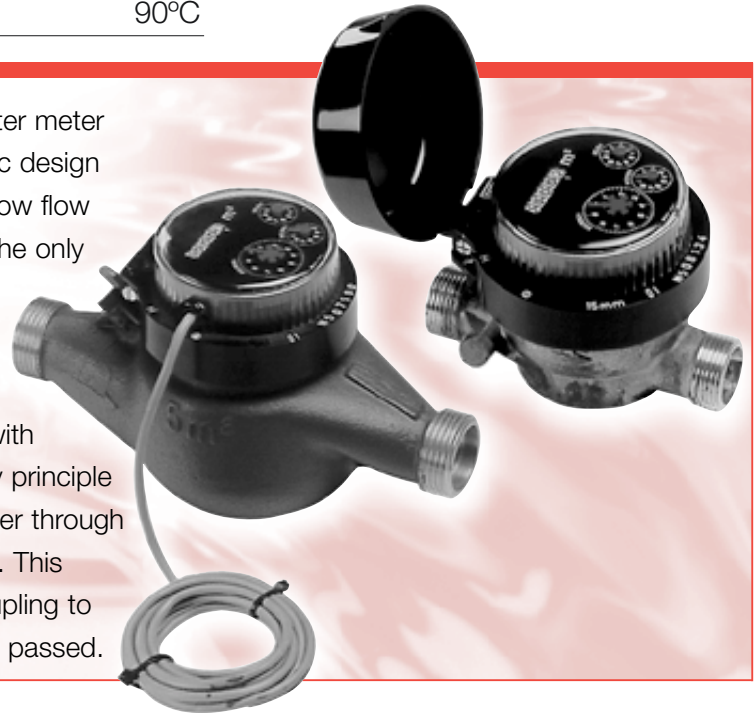

### Pulse unit

A standard feature of both models is a pulse output, in which the pulse unit is incorporated within the register, with the cable exiting from the side. The pulse element is a volt-free contact reed switch. Versions without a pulse output are also available.

### Standard features

- Tamper-resistant construction
- The register is dust-free, waterproof and vacuum-sealed to avoid condensation
- Numbered rollers show cubic metres, with pointers indicating litres
- Headloss is less than 1 bar at overload flow rate (qs)
- Suitable for water with above-average solids in suspension
- The rotor is suspended by hydrodynamic forces to give minimum load on the bearings
- The magnetic drive is unaffected by external magnetic interference
- Meter is supplied complete with connections
- Maximum working pressure of 16 bar

### Installation

The meter is installed with the direction of flow as indicated by the arrow cast in the meter body. A horizontal position with the register face upwards is recommended. No adjustments are necessary before installation as it is calibrated before despatch.

# S130 and M150

## Performance

### S130

### M150

Size of meter	mm	15	20	15	20	25	30	40	
Permanent flow rate	qp±2%	m³/h	1.5	2.5	1.5	2.5	3.5	6	10
Overload flow rate	qs±2%	m³/h	3	5	3	5	7	12	20
Transitional flow rate	qt±2%	l/h	100	200	120	200	280	400	800
Minimum flow rate	qmin±5%	l/h	25	50	30	50	70	100	200
Starting flow rate (approximately)		l/h	7	10	10	14	18	20	30
Headloss at qs	bar		1.0	1.0	1.0	1.0	1.0	1.0	1.0
Headloss at qp	bar		0.2	0.25	0.25	0.25	0.25	0.25	0.25
Metering capacity	m³		10000	10000	100000	100000	100000	100000	100000
Minimum scale value	litre		0.02	0.02	0.2	0.2	0.2	0.2	0.2

## Dimensions

Connection thread size	BSPT	inches	G½	G¾	G½	G¾	G1	G1¼	G1½
Meter thread size	BSP	inches	G¾	G1	G¾	G1	G1¼	G1½	G2
Length without connectors – L1		mm	115	115	190	190	260	260	300
Length with connectors – L2		mm	200	207	275	281	365	371	431
Height to centre line – H1		mm	19	19	32.5	40	47	47	58
Height lid open – H3		mm	138	138	165	170	185	185	210
Height lid closed – H2		mm	88	88	117	124	137	137	147
Width		mm	84	84	84	94	100	100	122
Weight without connectors		kg	0.60	0.70	1.35	1.5	2	2.1	3.3
Weight with connectors (approximately)		kg	0.77	0.96	1.52	1.80	2.51	2.91	4.35

## Pulse generator specification

Vmax	24V
Imax	200mA
Pmax	4W

## Frequency

S130	Pulse per litre (both sizes)
M150	Pulse per 10 litres (all sizes)
	Pulse per litre (15mm and 20mm only) to special order
Cable	2 core, 1.6m long, 4mm diameter, bare wire termination (flying lead)

## Materials of Construction

Body	Copper alloy 62%
Shaft	Stainless steel 18/8 / polyamide
Thimble filter	High density polyethylene
Measuring chamber	Polystyrene
Rotor	Polyamide 12
Lower plate	Polystyrene
Wet gear train	Graphited polyamide 12
Upper plate	Polyphenylene oxide glass loaded

## Sealing elements:

O ring	Elastomer / nitrile
Washer	Polyamide 6
Locking ring	acetal resin 25% glass loaded

## Register:

Case and bottom plate	Polycarbonate
Gears	Graphited polyamide 12
Rollers	Polystyrene
Number roller	ABS
Clamping ring	Polyamide 6
Lid	Polycarbonate

Compatibility with these materials of construction should be confirmed on treated water applications.

S130

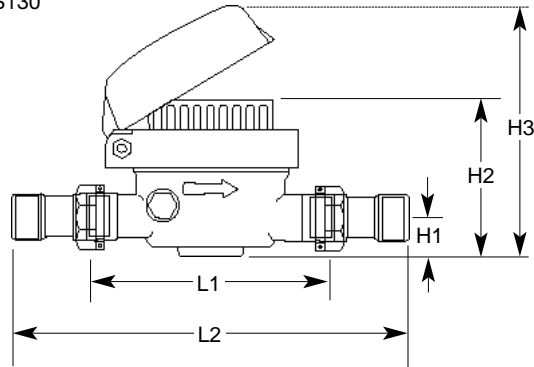

M150

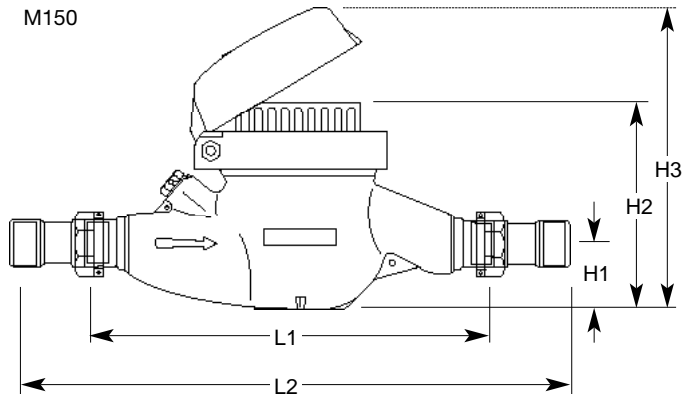

Elster Metering Limited  
 Pondwicks Road  
 Luton, Bedfordshire  
 LU1 3LJ, United Kingdom  
 Telephone +44 (0)1582 402020  
 Facsimile +44 (0)1582 438051  
 Website: www.elstermetering.com  
 E-mail: water.metering@gb.elster.com

## Pressure equipment directive 97/23/EC

This product is applicable in networks for the supply, distribution and discharge of water and associated equipment and is therefore exempt.

Leaflet ref. 8509B6333

The Company's policy is one of continuous improvement and the right is reserved to modify the specifications without notice.